

119/BAR/E

LISTA DI RICAMBI
LIST OF SPARE PARTS
LISTE DES PIECES DE RECHANGE
ERSATZETEIL - LISTE
LISTA DE REPUESTOS

I

Come consultare il MANUALE PARTI DI RICAMBIO:

Il **Manuale Parti di Ricambio** è costituito da **Tavole** grafiche e da **Tablelle**.

Tavole grafiche:

- Le tavole riportano il disegno esploso dei gruppi principali della macchina.
- La suddivisione delle tavole è identificata nella TAV.0.
- Ogni particolare di ricambio è identificato da un **numero di posizione, i numeri di posizione posti in un riquadro identificano i particolari di ricambio consigliati.**

Tablelle:

- Le tablelle riportano i **Numeri di Posizione, la Descrizione** ed il **Codice** del particolare.
- Nel caso in cui lo stesso numero di posizione sia riportato più volte, ma associato a codici differenti, è necessario, all'atto dell'ordine, specificare la matricola della macchina in possesso del cliente, al fine di identificare il codice del particolare da fornire.

Per ordinare uno o più particolari di ricambio identificare sulla TAV.0 la tavola in cui è rappresentato il gruppo macchina in cui è presente il particolare, identificare quindi sulla tavola il particolare ed il relativo numero di posizione, quindi ricercare sulle tablelle il numero di posizione ed il corrispondente codice.

GB

How o consult the SPARE PARTS MANUAL:

The **Spare Parts Manual** is made up of **Drawing Plates** and **Tables**.

Drawing Plates:

- The plates contain the exploded views of the main units comprising the machine.
- The subdivision of the plates is liste on "TAV.0".
- Each spare parts item is identified by a position number, position numbers found in a box indicate the spare parts items recommended.

Tables:

- The tables list the **Position numbers, Descriptions** and the **Codes** for items.
- When the same position number appears more than once, but is also associated with different codes, specify the serial number of the customer's machine when ordering for the purpose of identifying the code for the item to be supplied.

To order one or more spare part items, identify the plate on "TAV.0" representing the machine unit on which the item is located.

Locate the item on the plate and the corresponding position number as well. Then use the position number to locate the corresponding code on the table.

F

Comment consulter le LIVRET DES PIÈCES DÉTACHÉES:

Le livret des Pièces Détachées se compose de **Planches** et de **Tableaux**.

Planches:

- Les planches illustrent la vue éclatée des groupes principaux de la machine.
- La "TAV.0" illustre la subdivision des différentes planches.
- Chaque pièce détachée est identifiée par un numéro de repère; les numéros de repère en encadré identifient les pièces détachées conseillées.

Tableaux:

- Les tableaux indiquent les Numéros de repère, la Désignation des pièces et les Codes des pièces en question.
- Si la même numéro de repère indiqué plusieurs fois mais qu'il est associé à des codes différents, lors de la commande il faut préciser le numéro de série de la machine; cela permettra d'identifier le code de la pièce à fournir.

Pour commander une ou plusieurs pièces détachées, repérer sur la "TAV.0" la planche représentant le groupe dont fait partie la pièce, ensuite identifier la pièce en question sur la planche ainsi que son numéro de repère, puis rechercher sur les tableaux le numéro de repère et le code y relatif.

D

Hinweise für die Konsultation des ERSATZTEILHANDBUCHES

Das Ersatzteilhandbuch besteht aus graphischen **Abbildungen** und **Tabellen**.

Graphische Abbildungen:

- Die Abbildungen umfassen die Detailzeichnung der Hauptaggregate der Maschine
- Die Aufgliederung der Abbildungen ist in "TAV. 0" angegeben.
- Jedes Ersatzteildetail ist mit einer **Positionsnummer** identifiziert; **die eingerahmten Positionsnummern identifizieren die empfohlenen Ersatzteildetails.**

Tabellen:

- In den Tabellen sind die **Positionsnummern**, die **Beschreibung** und der **Code** des Teils aufgelistet.
- Ist dieselbe Positionsnummer mehrmals in Zusammenhang mit anderen Code angegeben, muß bei der Bestellung die Maschinenummer angegeben werden, um den Code des zu liefernden Ersatzteils ausfindig machen zu können.

Um eines oder mehrere Ersatzteile zu bestellen, anhand der "TAV.0" die Abb. feststellen, in der das Maschinenaggregat dargestellt ist, für das das Teil bestimmt ist; anhand dieser Abb. dann das Ersatzteil und die entspr. Positionsnummer identifizieren und schließlich in den Tabellen die Positionsnummer und den entspr. Code suchen.

E

COMO CONSULTAR EL MANUAL DE PIEZAS DE REPUESTO

El Manual Piezas de Repuesto está formado por **Tablas** gráficas y por **Cuadros**

Tablas gráficas

- Las tablas indican el dibujo expuesto individualmente en todos sus particulares (tridimensional) de los grupos principales de la máquina.
- La subdivisión de las tablas está identificada en la "TAV. 0".
- Cada pieza de repuesto se identifica por un **número de posición, los números de posición colocados en un recuadro identifican las piezas de repuesto aconsejadas.**

Cuadros

- Los Cuadros indican **los Números de Posición, la Descripción y el Código** de la pieza.
- En el caso de que el mismo número de posición esté indicado más de una vez, pero asociado a códigos diferentes, es necesario, en el momento del pedido, especificar la matrícula de la máquina que posee el cliente, con el fin de identificar el código de la pieza que hay que suministrar.

Al hacer el pedido de una o más piezas de repuesto, identificar en la "TAV. 0" la tabla en la que está representado el grupo máquina en donde se halla la pieza, por consiguiente identificar en la tabla la pieza y el relativo número de posición, después buscar en los cuadros el número de posición y el correspondiente código.

Pos.	Cod.	Descrizione	Description	Description	Bezeichnung	Descripción
005	118164050	MANIGLIA RUBINET.COMPL.BIANCA	FRONT LID HANDLE	POIGNEE PORTILLON	HANDGRIFF FRONTVERSCHLUSS	MANILLA PORTILLO
006	155162700	PERNO RUBINETTO	FRONT LID PIN	PIVOT PORTILLON	STIFT FRONTVERSCHLUSS	PERNO PORTILLO
007	118103060	CORPO PORTELLO BIANC.STP.11534	FRONT LID	PORTILLON	FRONTVERSCHLUSS	PORTILLO
008A	173105340	POMELLO LUNGO BIANCO	KNOB	POMMEAU	HANDGRIFF	POMO
011	582100109	TERMOSTATO DANFOSS 077B0432	THERMOSTAT	THERMOSTAT	THERMOSTAT	TERMOSTATO
019	131165720	CONDENSATORE ARIA "UL" ISC	AIR CONDENSER	CONDENSATEUR A AIR	LUFT KONDENSATOR	CONDENSADOR AIRE
021	142070900	AGITATORE 3X C D.85 SX	BEATER	AGITATEUR	RUEHRWERK	AGITADOR
024	157180680	CONTROAGITATORE 2E 097218002	IDLER BEATER SHAFT	CONTRE-AGITATEUR	GEGENRUEHRWERK	CONTRAAGITADOR
025G	173139120	TERMINALE AGITATORE G D.85 SX	BEATER END PUSHER (GRAVIT	TERMINALE AGITATEUR	RUEHRWERKENDE	TERMINAL AGITADOR
027	102159330	CASSETTINO SGOCC.L=380	DRIP DRAWER	CUVETTE EGOOUTTOIR	ABTROPFTASSE	CAJETIN RECOGE
028	177120160	PREMISTOPPA AGITATORE HYTREL	BEATER SHAFT SEAL	PRESSE ETOUPE AGITATEUR	WELLENDICHTUNG	PRENSAESTOPA AGITADOR
029	102164510	COPERCHIO FORO CASSETT.BIANCO	COVER	COUVERCLE	DECKEL	TAPA
030	118133130	PISTONE PORTELLO COMPLETO	FRONT LID PISTON	PISTON PORTILLON	KOLBEN	PISTON PORTILLO
043	118170530	COMANDO PISTONE	PISTON CONTROL	COMMANDE PISTON	KOLBENBETAETIGUNG	MANDO PISTON
047	171100520	VITE PRIGIONIERA	STUD	GOUJON FILETE	STIFTSCHRAUBE	TORNILLO PRISIONERO
049	171102200	BOTTONE ARRESTO MENSOLA	BUTTON SHELF STOP	GOUJON BLOCAGE CONSOLE	KNOPF KONSOLE	BOTON PARA PARADA REPISA
050	102133060	MENSOLA BIANCA	SHELF	CONSOLE	AUFLAGE	REPISA FRONTAL
051	129068460	PARASPRUZZI LEXAN BIANCO L=225	SPLASH GUARD	PARAFLAQUE	SPRITZSCHUTZ	SALPICADERO
052	129068010	CURSORE ESTERNO AGO ALIMENTAZ.	FEED TUBE SLEEVE	CURSEUR AIGUILLE ALIMENTA	LAEUFER	CURSOR
053	129070170	AGO ALIMENTAZIONE	FEED TUBE	AIGUILLE D'ALIMENTATION	SICKERROHR	AGUJA ALIMENTATION

Pos.	Cod.	Descrizione	Description	Description	Bezeichnung	Descripción
054	158210850	GUARNIZ.ANTERIORE	FRONT GASKET	GARNITURE ANT.	ZYLINDER DICHTUNG-VORNE	GUARNICION FRONTAL
072	193010060	ESTRATTORE OR	O-RING EXTRACTOR	EXTRACTEUR DE JOINTS	O-RING AUSHEBER	EXTRACTOR
140	581200820	CORPO VALV.SOLEN.EVR 3 032F3233	SOLENOID VALVE BODY	CORPS ELECTROVANNE	KOERPER MAGNETVENTIL	CUERPO ELECTROVALVULA
141	581201042	BOBINA VALV.SOLEN.24V- 50/60HZ	SOLENOID VALVE COIL	BOBINE ELECTROVANNE	SPULE MAGNETVENTIL	BOBINA ELECTROVALVULA
146	581400107	FILTRO DN 163S 023U4156	FILTER DRYER	FILTRE	FILTER	FILTRO
168	561142323	C.ASPERA J2192GK POE 220240/50/1	COMPRESSOR	COMPRESSEUR	KOMPRESSOR	COMPRESOR
170	551310167	M.OLMO R09R3028P-4M- 3508/H 23050601	FAN MOTOR	MOTEUR VENTILATEUR	VENTILATOR MOTOR	MOTOR VENTILADOR
171	574100321	TRASF.16 50VA 410-220-0/30- 10-0	TRANSFORMER	TRANSFORMATEUR	TRANSFORMATOR	TRANSFORMADOR
171A	574100302	TRASF.AMP.RAPP.1/1000 152050	TRANSFORMER	TRANSFORMATEUR	TRANSFORMATOR	TRANSFORMADOR
171B	574100312	TRASF.MONOF.15,5VA 24V/0- 11V	TRANSFORMER	TRANSFORMATEUR	TRANSFORMATOR	TRANSFORMADOR
173	571100203	CONTATTORE B12-30-10 24/50/60	CONTACTOR	CONTACTEUR	KONTAKTOR SCHUTZ	CONTACTOR
177	583100148	PRESS.DANF.CC20W 29/20 060F1130	PRESSURE SWITCH	PRESSOSTAT	DRUCKWAECHTER	PRESOSTATO
178	581101054	VALV.TERM.TES2 MOP 30 068Z3438	THERMOSTATIC VALVE	DETENDEUR THERMOSTATIQUE	THERMVENTIL	VALVULA TERMOSTATICA
186	192107440	DECALC.FRONTALE 160X320	FRONT DECAL	DECALCOMANIE FRONTALE	ABZIEHBILD	CALCOMANIA
186A	192107840	DECALC.PULSANT.BAR YO	PUSH BUTTON DECAL	DECALCOMANIE CLAVIER	ABZIEHBILD	CALCOMANIA
200	573810092	MICROPROC.ST62T25 VER.YO5126.HEX	MICROPROCESSOR	MICROPROCESSEUR	MIKROPROZESSOR	MICROPROCESADOR
214	171101020	VITE REGOLAZ.COMANDO PISTONE	SCREW	VIS	SCHRAUBE	TORNILLO
228	177130060	COPERTURA VALVOLA TERMOSTATICA	THERMOSTATIC VALVE COVER	COUVERTURE SOUPAPE THERM.	DECKEL THERMVENTIL	COBERTURA VALVULA TERMOST



119/BAR/E

Codice Macchina - Machine Code: 971517111

Ed. 01/99

Pos.	Cod.	Descrizione	Description	Description	Bezeichnung	Descripción
250	102144110	COPERCHIO VASCA LEXAN BIANCO	TANK COVER	COUVERCLE CUVE	BEHAELTERDECKEL	TAPA TANQUE
255	511528510	VITE TCCI M 5X 10 DIN85 A2	SCREW	VIS	SCHRAUBE	TORNILLO
282	158261100	RACCOGLITORE PORTELLO BIANCO	SPLUSH GUARD	COLLECTEUR	STAUBSCHUTZ	PROTECTOR GRUPO EROGACION
283	164050480	SOPPORTO RACCOGLITORE COMPLETO	SPLUSH GUARD BRACKET	SUPPORT	STAUBSCHUTZ- HALTERUNG	SOPORTE PROTECTOR GRUPO
430	141115560	ALETTA RASCHIANTE	SCRAPER BLADE	AILETTE AGITATEUR	RUEHRWERKSCHABER	ALETA AGITADOR
500	558420066	RIDUTT.TR19/S 1: 9 GAVAGNI	GEAR BOX	REDUCTEUR	GETRIEBE	REDUCTOR
537	581110611	ORIFICIO N° 01 068-2077	ORIFICE	ORIFICE	EINSPRITZDUESE	ORIFICIO
569	191105300	PANNEL.FR.CPL.111-173-161- 253	PANEL	PANNEAU	TAFEL	PANEL
575	573800543	PULSANT.MOD.111-173-161- 253 30CM	PUSH-BUTTON PANEL	CLAVIER	TASTATUR	CAJA DE PULSADORES
600	558420553	MR.MTR 19/S 1: 9 240/260/50/1	REDUCTION GEAR BOX	MOTO-REDUCTEUR	MOTORGETRIEBE	MOTORREDUCTOR
605	573700158	CENTRAL.UC-BAR-BAR YO	ELECTRONIC BOARD	CENTRALE ELECTRONIQUE	ELEKTRONISCHE STEUERKASTE	CENTRALITA ELECTRONICA
607	572910101	SONDA TS TIPO P09251 C.SILIC.	PROBE	SONDE	FUEHLER	SONDA
630	155146100	ASTA 1 LIVELLO ELETTRON.COMPL.	ELECTRONIC ROD LEVER	JAUGE NIVEAU ELECTRONIQUE	FUEHLER NIVEAU	VARILLA NIVEL ELECTRONICA
708	576200295	FUSIBILE OMEGA T 5X20 ST 630MA	FUSE	FUSIBLE	SICHERUNG	FUSIBLE
744	177230150	GOMMINO 097500001	RUBBER STOPPER	GOMME	GUMMIPUFFER	ALMOHADILLA DE CAUCHO
772A	599100115	SCOVOLINO D. 15X350	FINE BRUSH	ECOUVILLON	REINIGUNGSBUERSTE	CEPILLO
772B	599100120	SCOVOLINO D. 20X450	FINE BRUSH	ECOUVILLON	REINIGUNGSBUERSTE	CEPILLO
772C	599100140	SCOVOLINO D. 40X400	FINE BRUSH	ECOUVILLON	REINIGUNGSBUERSTE	CEPILLO
830	743000111	TUBETTO GELILUBE 3540	GELILUBE LUBRICANT	TUBE DE VASELINE	GELILUBE-TUBE	TUBO GELILUBE
840	178600110	SPATOLA PULIZIA (CARPIGIANI)	CLEANING- SPATULA	SPATULE	SPATEL	PALETA DE LIMPIEZA



119/BAR/E

Codice Macchina - Machine Code: 971517111

Ed. 01/99

Pos.	Cod.	Descrizione	Description	Description	Bezeichnung	Descripcìon
850	193200640	SERIE ANELLI OR	O-RING SET	JOINTS OR	OR RING	JUNTAS OR
912	552820552	M.LME 71L4-4P 220/230/50/1	MOTOR FOR GEAR MOTOR	MOTEUR POUR REDUCTEUR	MOTOR FUER MOTORGETRIEBE	MOTOR MOTORREDUCTOR
920A	572910173	SENSORE PROSSIM.XUB- J083135	SENSOR LEVEL	DETECTUER DE PROXIMITE	ANNAEHERUNG FUEHLER	DETECTOR DE PROXIMIDAD
921	572910140	SONDA DRY REED N.O. 29	SAFETY SWITCH	SONDE DRY REED	REEDFUEHLER	SONDA DRY REED
1116	541000116	OR 1,78 15,6 NB 70 2062	O-RING	JOINT OR	OR-DICHTUNG	JUNTA OR
1153	541000153	OR 3,53 26,58 NB 70 4106	O-RING	JOINT OR	OR-DICHTUNG	JUNTA OR
1188	541000188	OR 5,34 91,44 NB 40 6362	O-RING	JOINT OR	OR-DICHTUNG	JUNTA OR
1285	541000285	OR 3,53 4,34 NB 70 0462	O-RING	JOINT OR	OR-DICHTUNG	JUNTA OR

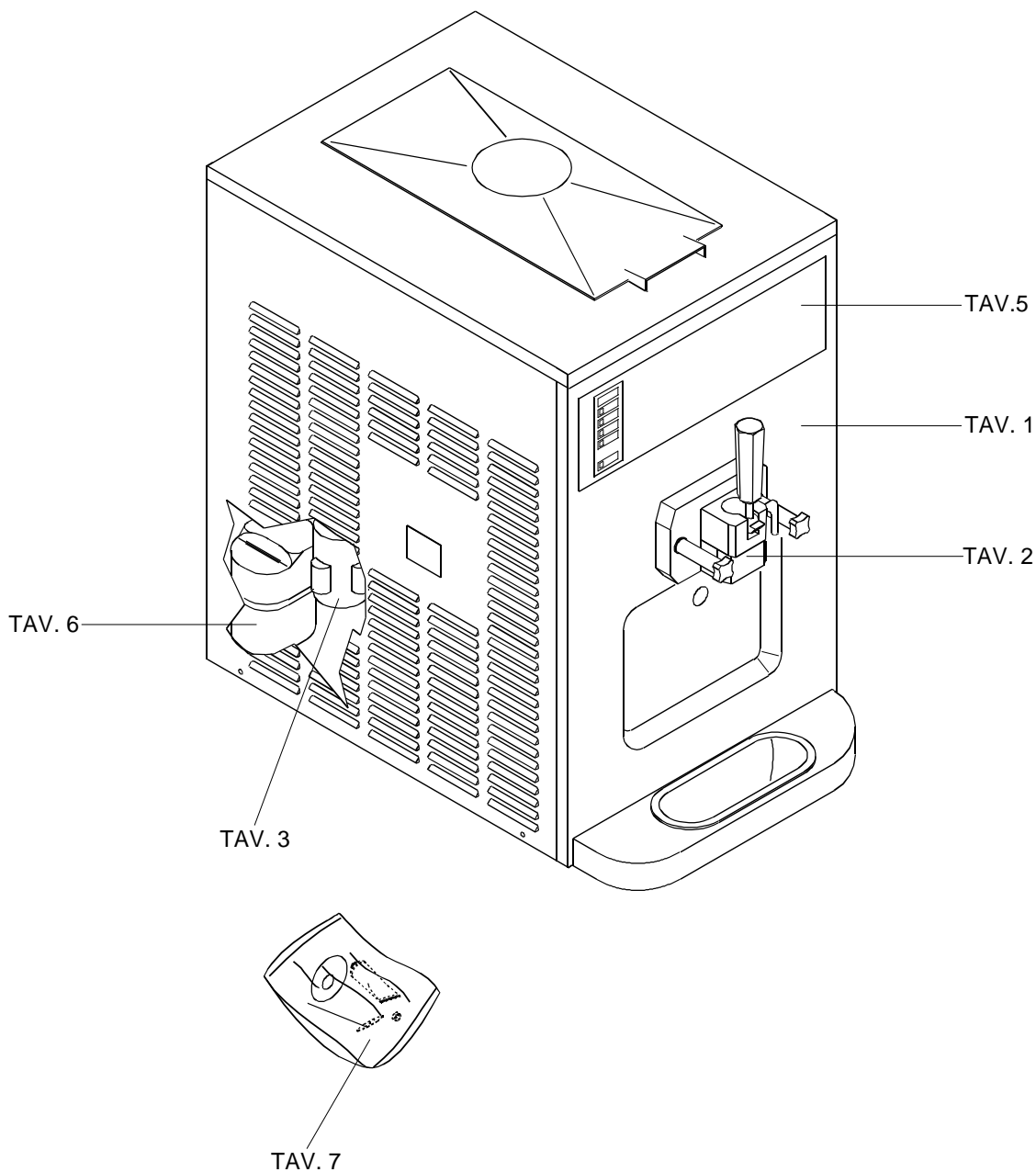

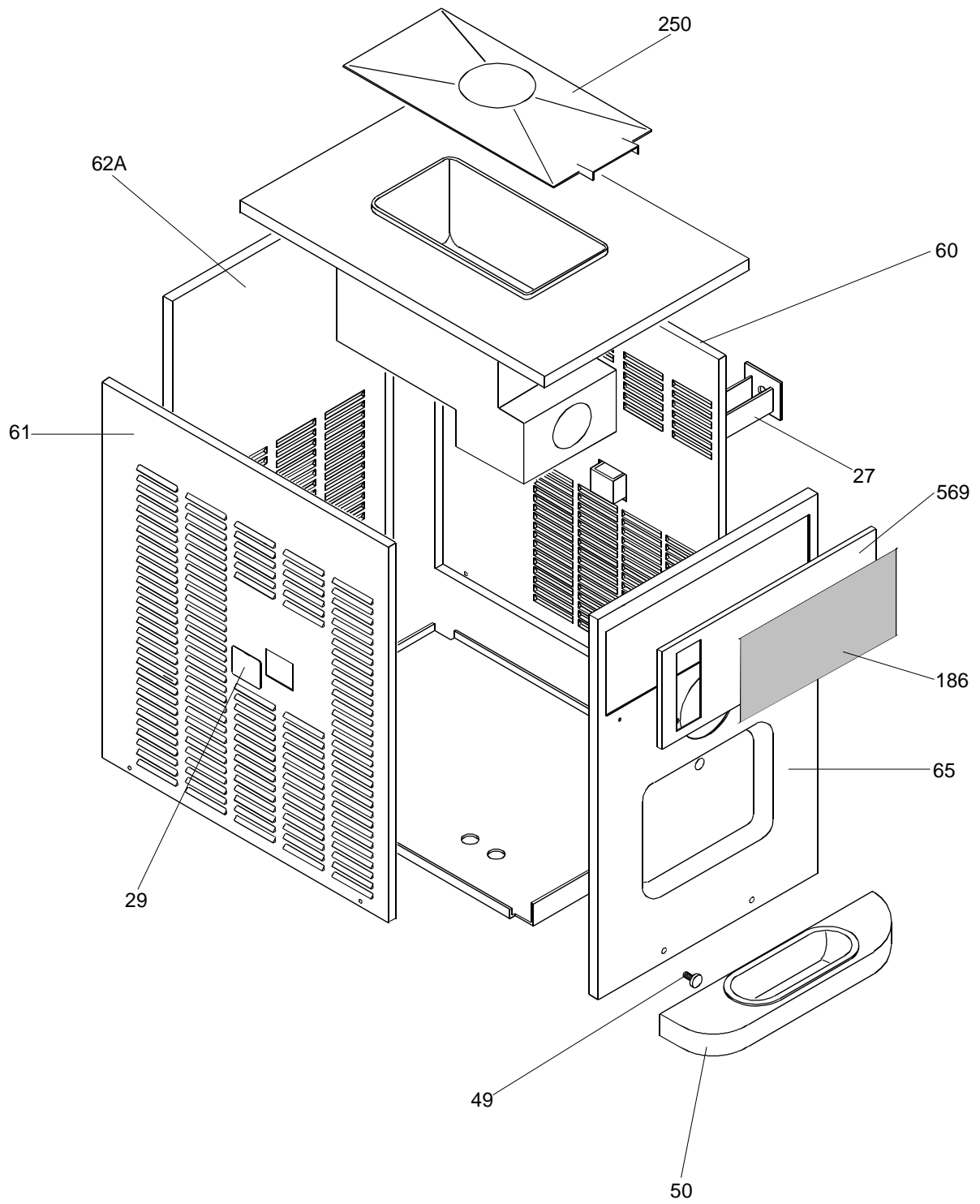

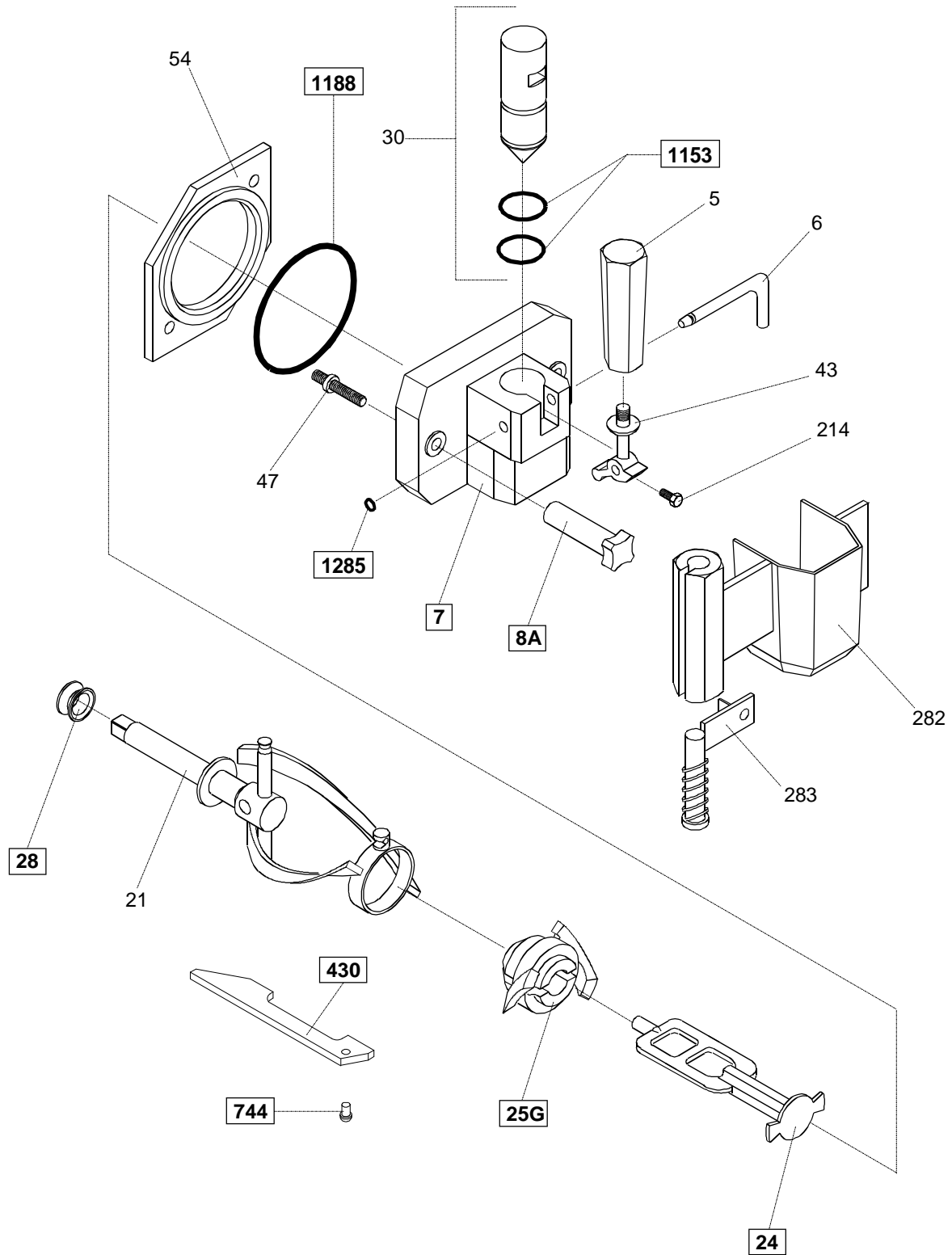

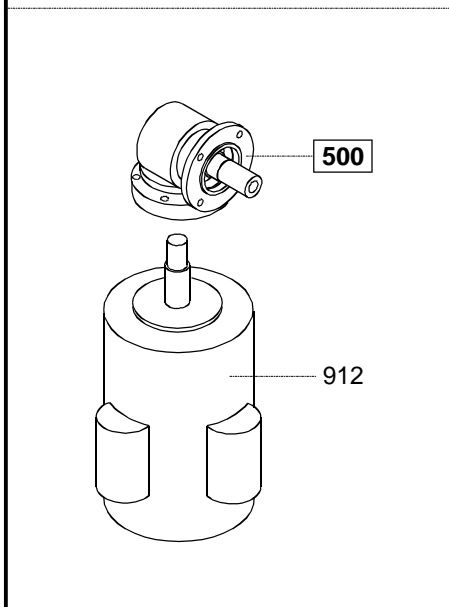
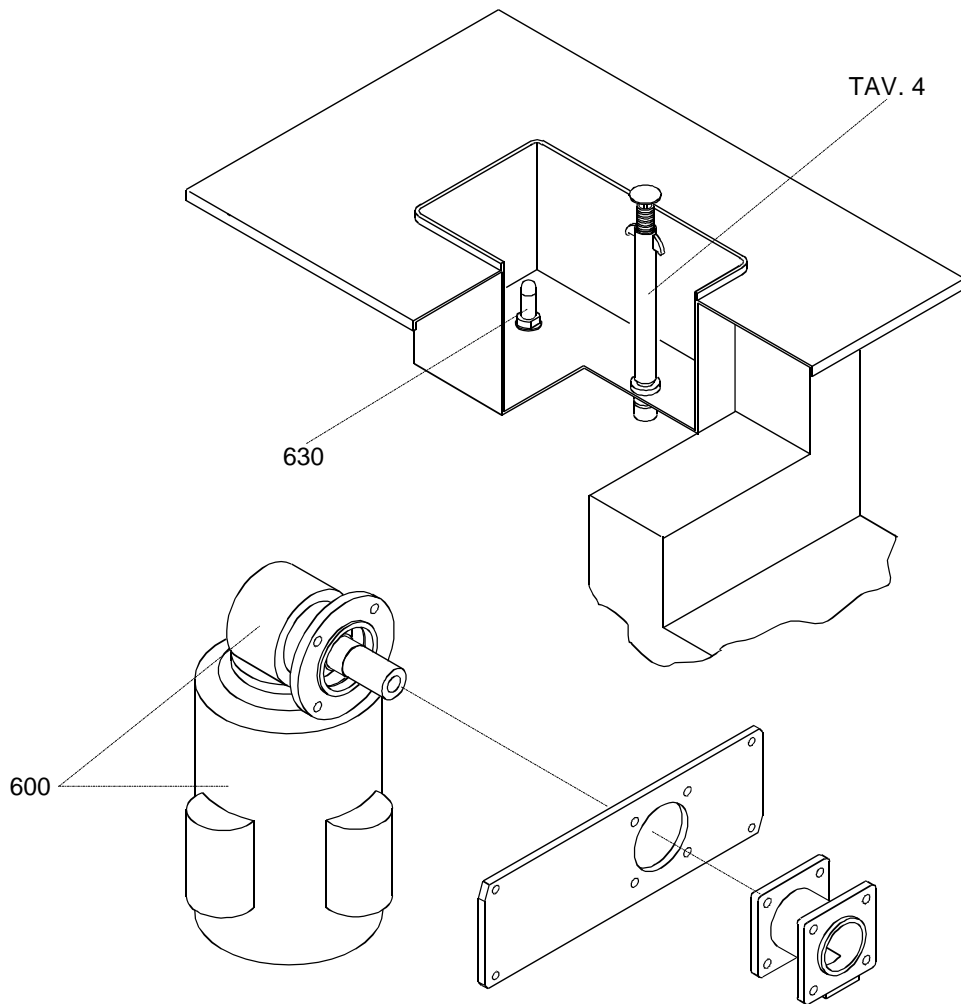

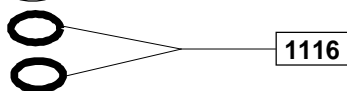
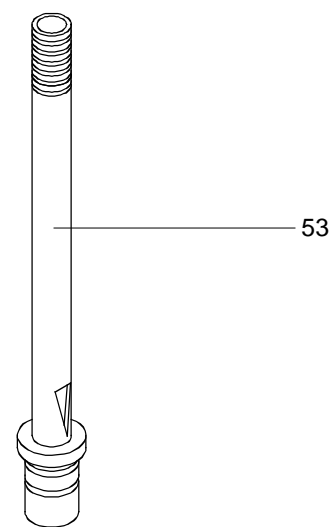
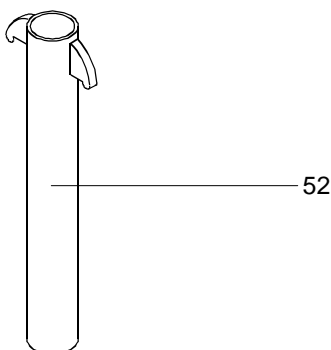
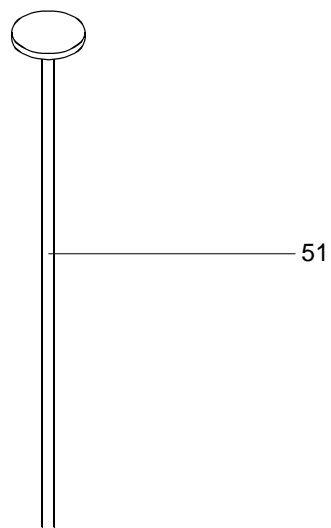

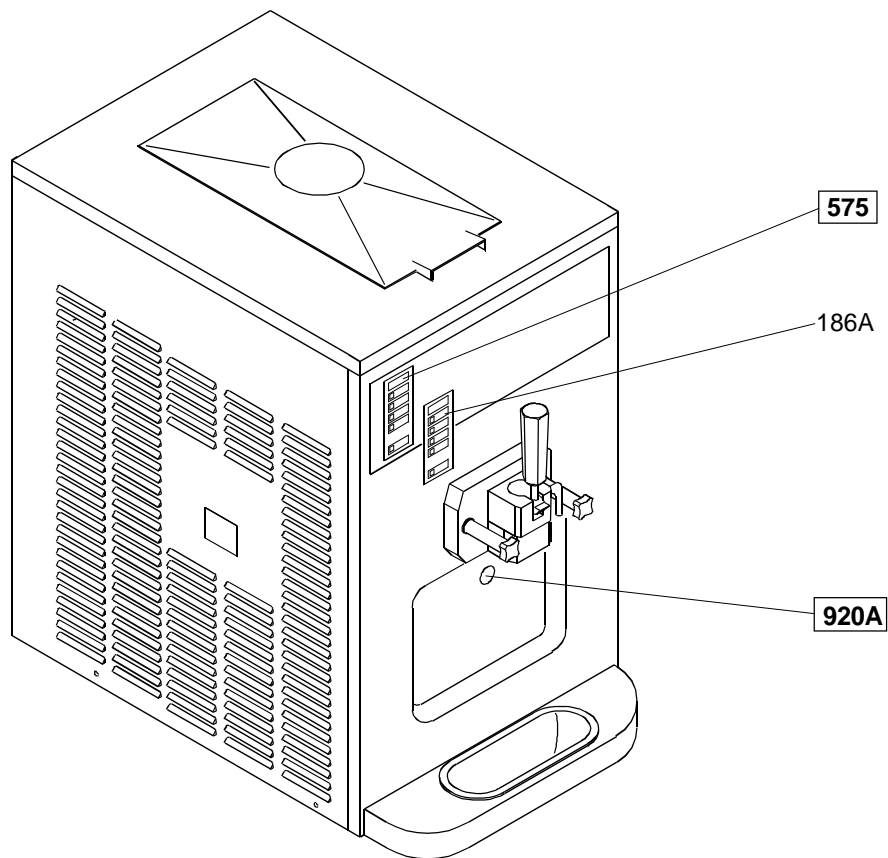
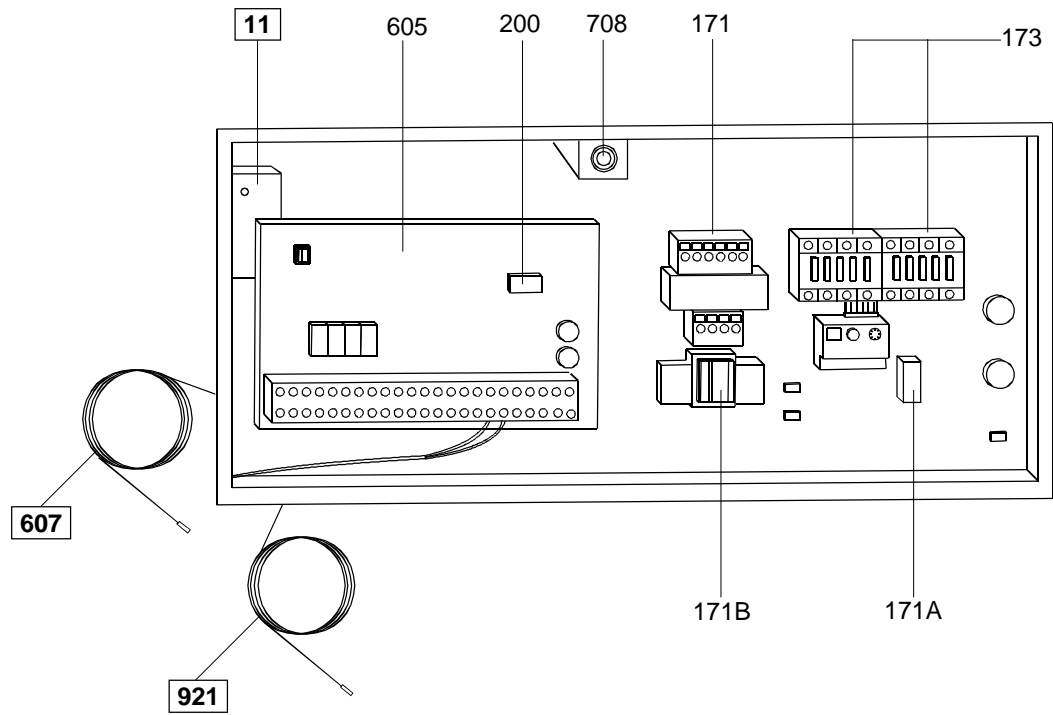

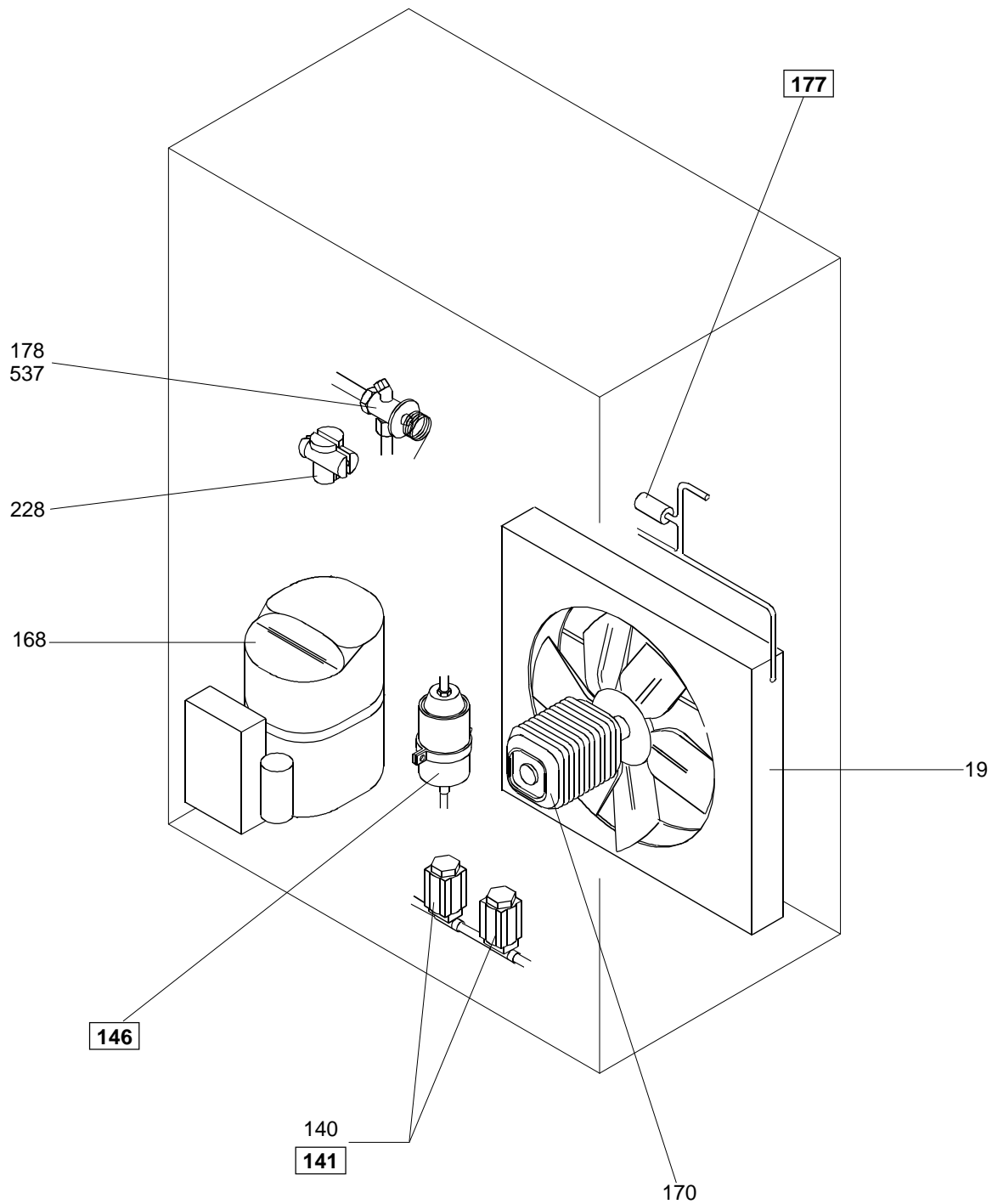

1188

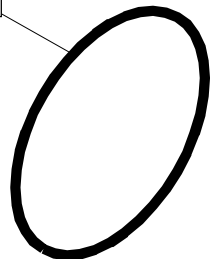

772C

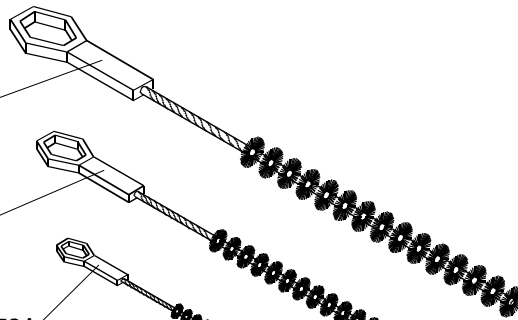

772B

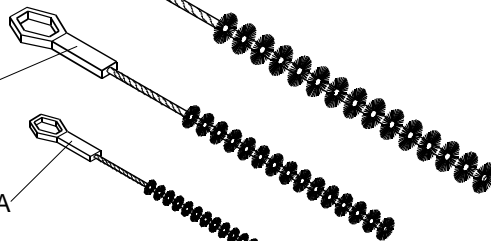

772A

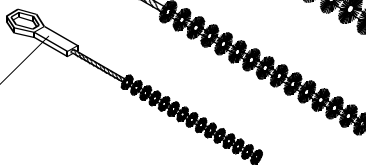

72

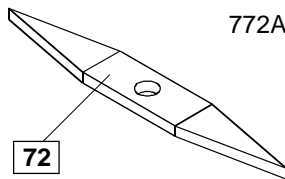

840

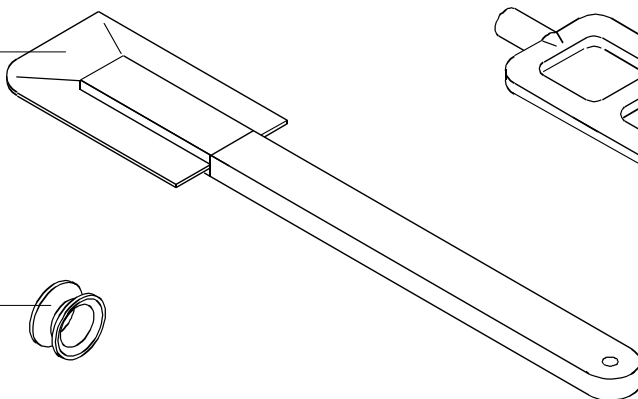

24

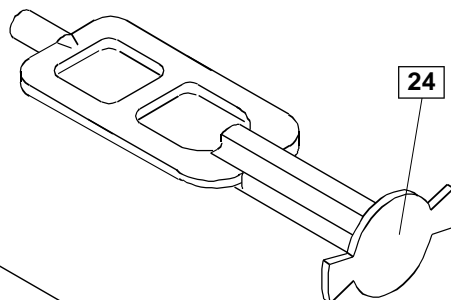

28



255

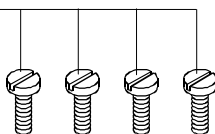

744



1116



1153



830

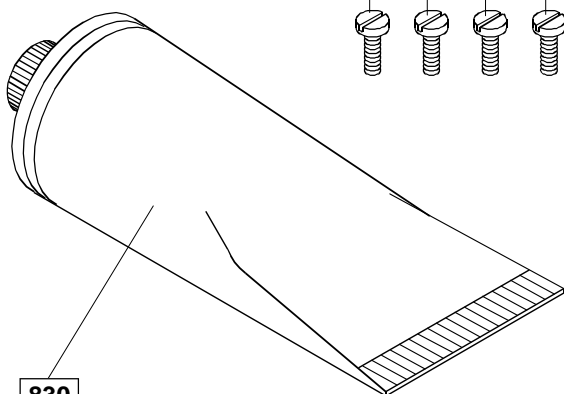



CARPIGIANI - ALI GROUP S.p.A.
Via Emilia, 45
40011 Anzola Emilia (Bologna) - Italy
Tel. (051) 6505111
Fax (051) 732178

Carpigiani si riserva il diritto di effettuare modifiche e/o revisioni del presente documento senza obbligo di preavviso.
Carpigiani reserves the right to make change and/or revisions of this document without being bound to previously notify it.
Carpigiani se réserve le droit d'apporter toutes modification et mises à jour jugées nécessaires et ce, à tout moment et sans obligation de préavis.
Carpigiani behält sich das Rech vor, jederzeit Änderungen ohne Voranzeige vorzunehmen.
Carpigiani se reserva el derecho de efectuar modificaciones y actualizaciones todas la veces que lo considere necesario sin la obligación de peraviso.